

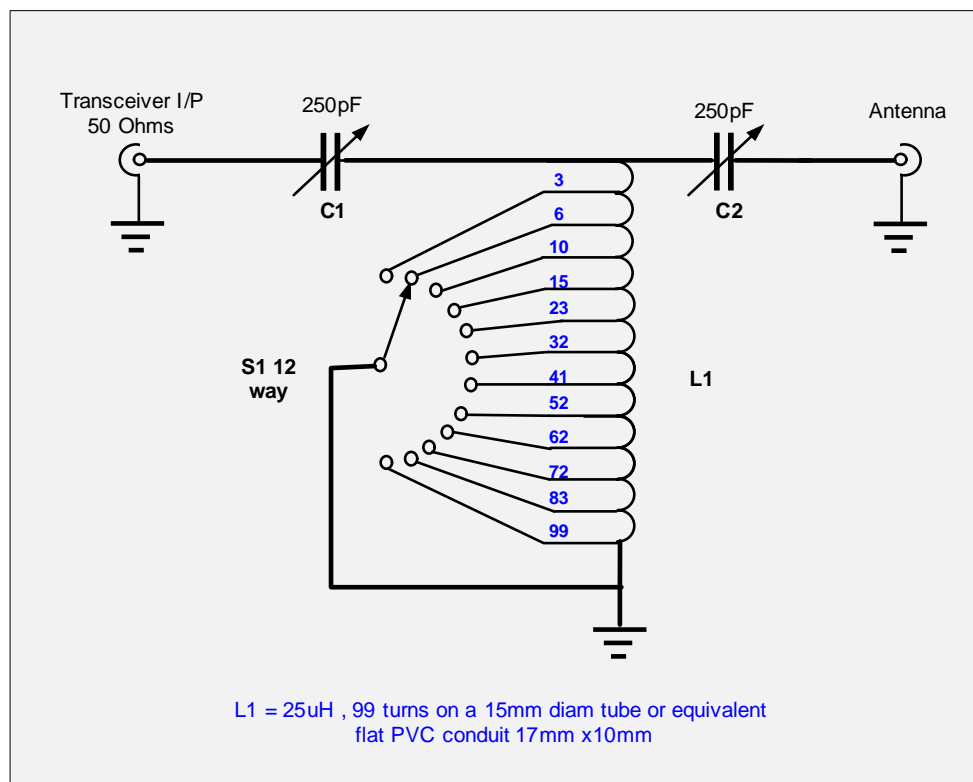

The BREMI Antenna Matcher designed for CB 27MHz was a £1.00 bargain from the October Kempton Park rally. It is a “T” antenna matching device with two SO239 connectors soldered to a paxolin PCB. An etched spiral inductor connects the two Varicon 250pF capacitors.

The intention was to adapt it for use with a Yaesu FT-817 QRP rig. Rick McKee KC8AON, a fellow member of the FT-817 Yahoo Group, designed a MINI-T-Match Tuner using two 300pF capacitors and a 35 turn coil on a 1" ( 25.4mm) former. Rick's design is by no means original, but became the starting point for this project to convert the BREMI into an HF T-Match design



### Design Considerations

The challenge was to design an inductor to work with the existing capacitors and fit it into the available space. To calculate the required inductance the on-line inductor calculator at <http://hamwaves.com/antennas/inductance.html> was used.

Rick's 35 turn 25.4mm coil had a calculated inductance of 19uH. However, in the Breimi case, there is only space for a former of about half that size. Using the on-line calculator again, a circular 15mm diameter tube 118mm long would require 90 turns of 0.9mm wire for 20uH. The wire for this was provided by 3 pair indoor telephony cable, which uses thin single core plastic coated wire. A test winding of 90 turns with no taps easily fitted the 118 mm long tube and the inductance came to 20uH.

## BREMI BRL15 ANTENNA MATCHER – Modification for HF Bands



### Making the Tapped Coil - for the MKII coil see later.

To create a neat tap, the wire was cut about 10mm beyond the tapping point. 10mm of insulation was stripped from both wires and the bare ends were twisted together and soldered. Once the wires are soldered, winding is continued and a neat pre-soldered tap is left behind. The same method was used to create the remaining taps. A trial 12 tap coil was made to test the modified tuner's capabilities



### Preparing the new 12-way switch.

The design uses a single pole 12 way switch, but requires careful measuring to position and drill the two new holes ( 10 mm & 2,5mm), used to secure the switch in its final position. The switch shaft is cut slightly longer than that of the capacitors so that the switch knob is slightly proud of the existing capacitor knobs, making it easier to operate the switch. This can be seen in the accompanying pictures.

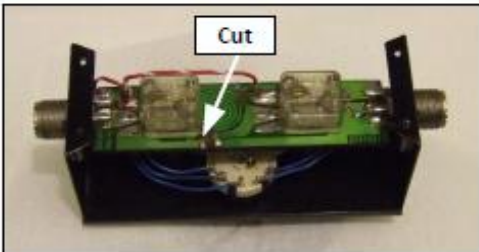

### Modifying the original PCB.

Having prepared the new parts, it is necessary to modify the PCB. Using a sharp scalpel isolate the original PCB and the two bridging links, which connect the capacitors to the SO239 sockets. The photo shows where one of the cuts is made to isolate the original inductor.



### Fitting the 12-way switch & wires.

For ease of construction, the 12-way switch is pre-wired before it is installed in the Bremi chassis. The knob is fitted and the wire ends dressed in ascending order ready for mating onto the inductor taps, prior to soldering. The new inductor coil is then installed. It is a push fit and will be firmly held in place once the wires are soldered to it.

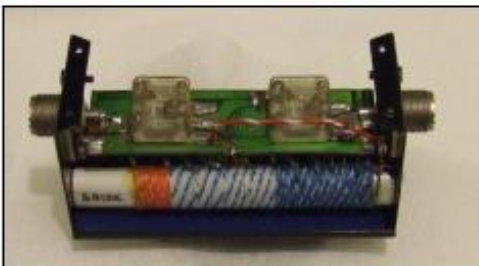

### Soldering the wires to the inductor.

Having seated the inductor firmly (push fit), starting with the first connection on the pre-wired switch, each wire is trimmed, removing most of the slack, and soldered to the tapping points on the inductor. Finally the bottom connection of the coil is soldered to the ground connection that is also connected to the outer shell of the two SO239 sockets.

### Initial Testing and Results.

Once the modification is complete it needs to be tested. This modification was tested using an existing multi-band G5RV antenna and an end fed 20m wire with a Kenwood TS50, running 10 watts. This is double the power of the FT-817 QRP rig and thus provided a good safety margin before testing the device with the FT-817. It was not possible to match the G5RV on 20M and the SWR was >2:1. This was due to insufficient inductance and a Mark II coil was wound, increasing the inductance to 25 uH with 99 turns. The new coil is tapped at 3, 6, 10, 15, 23, 32, 41, 52, 62, 72, 83 and 99 turns.

## BREMI BRL15 ANTENNA MATCHER – Modification for HF Bands



Unfortunately, during the re-testing of the MKII inductor coil a solder splash caused arcing and the original paxolin PCB was charred. A new glass fibre PCB was made to salvage the project but with wider spacing between tracks as shown below.

### The final version results.

It is possible to tune the G5RV on all the HF Bands between 80m and 10m. Following this success, the device was tested with a 42 inch telescopic whip – shown in the accompanying picture. With a bit of practice, this would also tune on 80-10m bands. Certainly, this is not the best antenna, but the matching device was able to “tune” it. It is not as efficient as a full size antenna, but it did receive reasonably well. Similar successes were obtained with a 3m and a 6m wire strung to a nearby bush about 2 metres above the lawn and of course the obligatory counterpoise of a similar size



### How to make a Printed Circuit Board (PCB).

The fibreglass printed circuit board (PCB) is easy to make. The copper side is cleaned using a soap impregnated wire wool pad normally used in the kitchen for scrubbing pans. The board is washed in water and again in alcohol to ensure the surface is degreased. This ensures that the ferric chloride solution is able to work on the exposed clean copper. The PCB is completely covered with white electrical insulation tape that is firmly pressed onto the copper surface. Using a ball point pen, the copper tracks are marked on the tape and the area to be removed is shaded to identify it. Using a scalpel or sharp knife cut along the lines around the shaded areas. Press down on the tape again to ensure it is firmly stuck to the copper before putting the PCB into the etching solution. Remove the shaded white tape to expose the copper areas to be removed.

The etching solution used for this is made by dissolving brown ferric chloride crystals in warm water in a plastic or glass dish. (carefully follow the suppliers instructions when doing this). Finally immerse the PCB face up in the solution and agitate from time to time to ensure that the copper is removed evenly. After about half an hour the etching process is usually completed and the PCB is removed and washed in warm water. The white electrical tape is removed to expose the PCB copper tracks as shown below. The tracks should be tinned to protect the copper using flux to help the solder to spread thinly and evenly over the copper.

### WARNING:-

*Ferric chloride splashes will stain and cause skin irritation.  
Read the instructions carefully before using the product*



**In conclusion the project was a joy to build, cost very little and works really well.**



Modifying the original Bremi Antenna Matcher Paxolin PCB



**Note :-**  
 Take care when cleaning fluid to remove excess solder flux. This can get trapped under the plastic cover of the capacitor, or the between capacitor's vanes. To avoid the risk of arcing that can carbonise Paxolin PCB ensure that all the cleaning fluid has totally evaporated before testing the matcher on an antenna

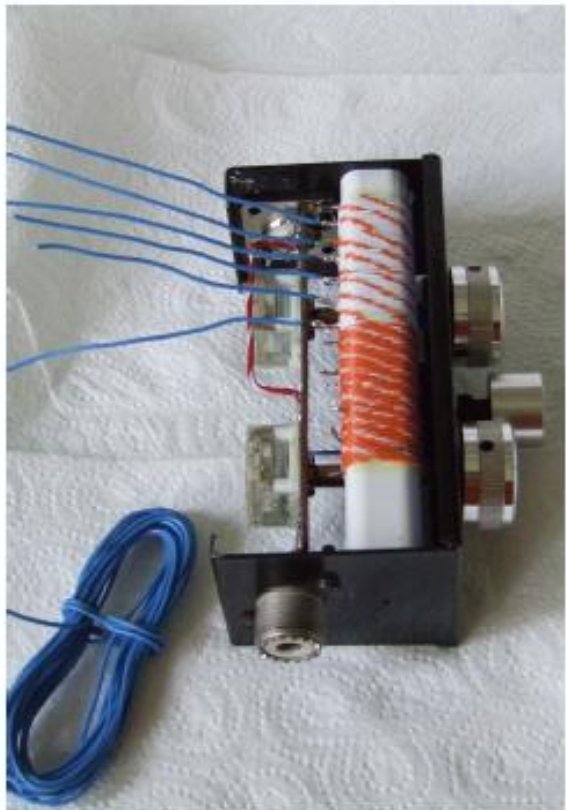
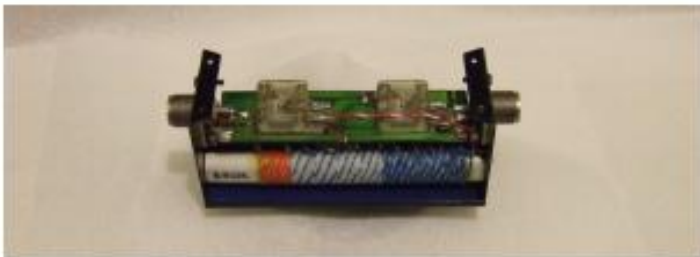
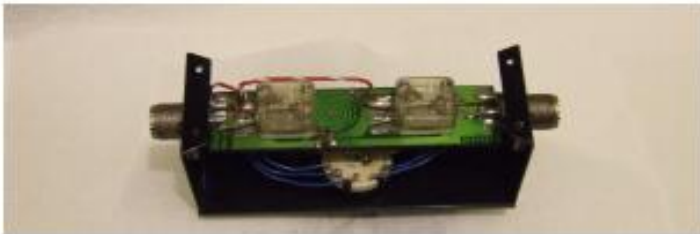

**BREMI CB TUNER MOD BY G8ODE for Amateur Radio 80-10M bands**

The capacitors are left in situ, the spiral inductor is isolated by cutting tracks, and both capacitors centre tags are connected to the centre pin of the SO239. The outer two contacts of the tuning capacitors are in fact connected on the original PCB. These need linking as shown with the red-white striped wire. A 12 way switch is added, and the common contact is connected to the ground rail (outer of the SO239). The 12 contacts of the switch are connected to each of the coil taps. The coil is plastic conduit 17 x10 mm but 15 mm diam tube could be used. You need 99 turns for the coil. (makes a 25 uH inductor) Tap at 3, 4, 6, 8, 10 .....11. 14 and so on experiment. The capacitors were 250 PF. There is also a small disc capacitor on the BREMI PCB this need to be removed.